

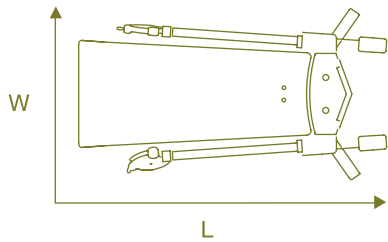

selectorized LIFT



specifications	GZFM6012			
<p>effective resistance: 1 arm - 100 lbs. (45.5 kg) 2 arms - 200 lbs. (91 kg)</p> <p>configuration: 5 - 50 x 5 lbs. (2.25 - 22.75 x 2.25 kg) 60 - 200 x 10 lbs. (27.25 - 91 x 4.5 kg)</p>	<p>US / METRIC L - 76" / 193 cm W - 42" / 107 cm H - 73" / 185 cm</p> <p>940 lbs. / 427 kg</p> <p>cable diameter: 3/16-inch rated to 2,000 lbs.</p>			

Swivel Pulleys - Pulley design ensures fluid cable travel and provides nearly unlimited range of motion.

Independently Adjustable Arms - Arms adjust vertically in six settings, allowing users to perform a wide variety of exercises.

Textured Platform - Unique platform with grip texture helps to ensure stable foot positioning.

Cable Travel - Extensive cable travel allows for full exercise extension or flexion, single arm: 120 inches (305 cm), two arms: 60 inches (152 cm).

Weight Stack - Enclosed weight stack limits access to moving parts for user safety.

Industrial Construction - Equipment is built with 11- and 7-gauge steel and is electrostatically powder-coated.

Kick Plates - 16-gauge, stainless steel kick plates protect the machine from wear and tear.