

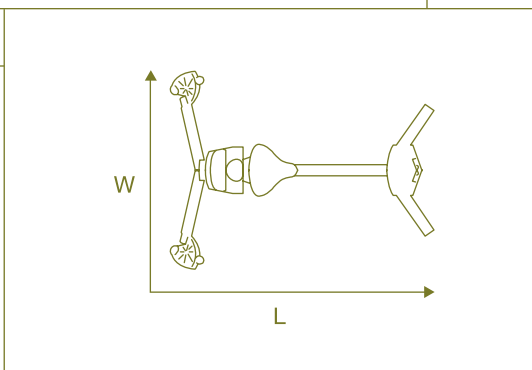

selectorized CHEST



specifications	GZFM6000
<p>effective resistance: 1 arm - 100 lbs. (45.5 kg) 2 arms - 200 lbs. (91 kg)</p> <p>configuration: 5 - 50 x 5 lbs. (2.25 - 22.75 x 2.25 kg) 60 - 200 x 10 lbs. (27.25 - 91 x 4.5 kg)</p>	<p>US / METRIC L - 71" / 180 cm W - 53" / 135 cm H - 73" / 185 cm</p> <p>530 lbs. / 241 kg</p> <p>cable diameter: 3/16-inch rated to 2,000 lbs.</p>



Swivel Pulleys - Pulley design ensures fluid cable travel and provides nearly unlimited range of motion.

Independent Arm Movement - Handles move independently for a wide variety of chest exercises and single arm movements.

Traditional Seated Position - A supported position is ideal for traditional and first-time exercisers. To further challenge the body, advanced users may perform exercises off the backrest or standing.

Cable Travel - Extensive cable travel allows for full exercise extension, single arm: 76 inches (193 cm), two arms: 38 inches (96.5 cm).

ADA Compliant - Compliant with Americans with Disabilities Act for wheelchair accessibility.

Weight Stack - Enclosed weight stack limits access to moving parts for user safety.

Industrial Construction - Equipment is built with 11- and 7-gauge steel and is electrostatically powder-coated.

Kick Plates - 16-gauge, stainless steel kick plates protect the machine from wear and tear.