

selectorized **CABLE CROSS**

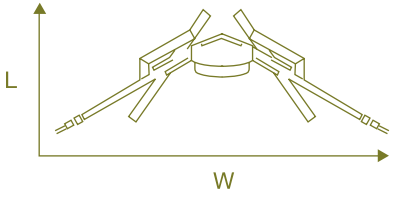

specifications	GZFM6006	
<p>effective resistance: 1 arm - 75 lbs. (34 kg) 2 arms - 150 lbs. (68 kg)</p> <p>configuration: 5 - 50 x 5 lbs. (2.25 - 22.75 x 2.25 kg) 60 - 150 x 10 lbs. (27.25 - 68.25 x 4.5 kg)</p>	<p>US / METRIC L - 38" / 97 cm W - 112" / 284 cm H - 95" / 241 cm</p> <p>810 lbs. / 368 kg</p> <p>cable diameter: 3/16-inch rated to 2,000 lbs.</p>	

Swivel Pulleys - Pulley design ensures fluid cable travel and provides nearly unlimited range of motion.

Independently Rotating Arms - Each arm rotates and has numerous settings to accommodate virtually any movement pattern. Arms are counterbalanced for easy positioning.

Independently Moving Handles - Handles can move independently for virtually unlimited exercises.

ADA Compliant - Compliant with Americans with Disabilities Act for wheelchair accessibility.

Cable Travel - Extensive cable travel allows for full exercise extension or flexion, single arm: 144 inches (366 cm), two arms: 72 inches (183 cm).

Weight Stack - Enclosed weight stack limits access to moving parts for user safety.

Industrial Construction - Equipment is built with 11- and 7-gauge steel and is electrostatically powder-coated.

Kick Plates - 16-gauge, stainless steel kick plates protect the machine from wear and tear.